

INSTRUCTIONS FOR USE

EQUIPMENT

- Personal Protection Equipment (not supplied by SeaShield)
- Surface Preparation Equipment (not supplied by SeaShield)
- Cutting tool (not supplied by SeaShield)
- Denso Paste S105™
- SeaShield™ Marine Piling Tape
- Densyl™ Mastic or Densyl™ Mastic Blankets (as required)
- Bitumen Outerwrap
- Denso™ PVC Self-Adhesive Tape

HANDLING AND STORAGE

- All materials shall be stored upright in their original packaging, out of direct sunlight.
- All materials shall be stored in a cool dry place between 5°C and 35°C – (Note standard grades of Bitumen Outerwrap shall be stored between 5°C and 20°C).
- All tools shall be stored in their original packaging, in a cool dry place out of direct sunlight between 5°C and 35°C.
- Please read the Safety Data Sheet for all materials before commencing application.

DISPOSAL

Please minimise or avoid waste wherever possible. Please do not discard waste material, including packaging, in the surrounding environment. Follow all relevant legislation for disposal.

IMPORTANT:

Winn & Coales (Denso) Ltd pursue a policy to develop and continually improve all of our products and therefore information given in this data sheet is intended as a general guide and does not constitute a warranty, specification or risk assessment. These guidelines may not cover all circumstances; however, our sales personnel are committed to assisting the user in establishing the suitability of the product for its intended purpose and additional specific information, including Safety Data Sheets, is available on request. We recommend that installation is carried out with due regard to Health and Safety and in accordance with relevant local statutes and regulations. Any conflict between these guidelines and the specific project specifications must be resolved by the user before work commences. All rights reserved.

CORROSION CONTROL FOR JETTY PILES & MARINE STRUCTURES**SURFACE PREPARATION****METHODS AND EQUIPMENT**

The following methods may be used:

- Hand tool cleaning.
- Power tool cleaning.
- High pressure water jetting.
- Abrasive blast cleaning.
- Other methods by agreement.

The following shall be considered:

- The degree of marine growth on the pile or bracing.
- The degree of corrosion on the pile or bracing.
- Any existing corrosion prevention coatings on the pile or bracing.
- Any hot working or spark restrictions at the site.
- Any environmental restrictions at the site.
- The reduction of debris being deposited into the marine environment.
- Any other considerations specific to the site.

DEGREE OF CLEANING**Metal:**

- All loose corrosion products must be removed.
- All mill scale must be removed.
- Protrusions must be ground smooth to remove sharp edges and sudden changes of profile. Care shall be taken to avoid damage to the weld seam.

Concrete:

- All loose concrete must be removed.
- All concrete laitance must be removed.
- Protrusions must be ground smooth to remove sharp edges and sudden changes of profile.

Timber:

- All loose timber must be removed.
- Protrusions must be ground smooth to remove sharp edges and sudden changes of profile.

Existing corrosion prevention coatings:

- All loose corrosion prevention coatings must be removed.
- Tightly adhering corrosion prevention coatings can remain on the surface of the pile.

Marine growth:

All living marine growth must be removed. Marine biofilm can establish on the surface of a pile within 24 hours. Groups of piles may have heavy levels of marine growth and other contamination removed as a "batch". If that "batch" of piles are then not wrapped with a SeaShield system within 24 hours, it is required as a minimum to wire brush the surface of the pile to remove any biofilm that may have formed.

Non-living, tightly adhering mineral deposits caused by shellfish or similar can remain on the surface of the pile.

The surface of the pile can be washed with seawater as required to aid in achieving the above requirements.



Example image of an acceptable level of surface preparation.



Example image of a pile featuring loose corrosion that would require removal.



Example image of a pile featuring a loosely adhering corrosion prevention coating that would require removal.



Example image showing tightly adhering corrosion prevention coating and corrosion (orange rust) that would **not** require removal.

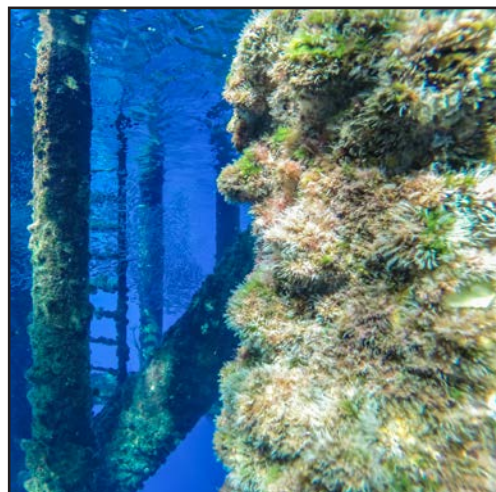

Example image of marine growth.



Example image of marine biofilm.



Example image of a pile featuring acceptable levels of non-living, tightly adhering mineral deposits.

PASTE S105 APPLICATION**DEEP PITS**

A deep pit is defined as a pit of 2.0mm or greater, where there is a risk that the Marine Piling Tape will 'bridge' the pit, creating a void. These pits shall be filled with Paste S105 to prevent there being a void (see Fig. 1).

Should there be a very deep pit, or should it be otherwise difficult to fill a deep pit with Paste S105, a thin film of Paste S105 shall be applied into the pit followed by a patch of Marine Piling Tape which shall be pressed firmly into the pit to prevent there being a void (see Fig. 2).

Paste S105 can be applied by various means to fill deep pits such as, flexible filling knife, trowel, gloved hand, roller, brush, or other means as agreed.

LARGE WELD BEAD

A large weld bead is defined as a weld bead of 2.0mm height or greater, where there is a risk that the Marine Piling Tape will 'bridge' the weld bead, creating a void.

Paste S105 shall be applied along either side of a weld bead, to prevent there being a void (see Fig. 3).

GENERAL PRIMING

Paste S105 shall be used as a general primer on the pile. A thin layer of Paste S105 shall be applied over the area for protection. Paste S105 can be applied by various means to act as a primer such as, gloved hand, roller, brush, or other means as agreed.

The purpose of Paste S105 as a primer is to assist with displacement of water from the surface of the pile. There is no minimum requirement for the thickness of the Paste S105 layer. A thick layer of Paste S105 is not recommended or required.

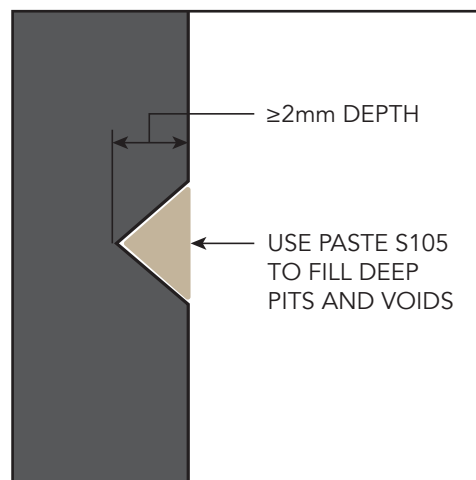

Fig. 1: Filling deep pits of 2.0mm, or greater, depth.

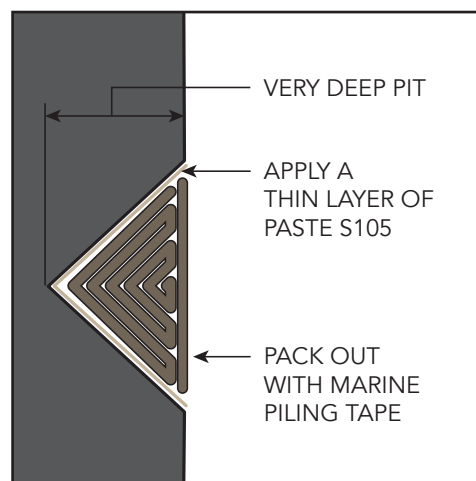

Fig. 2: Filling very deep pits.

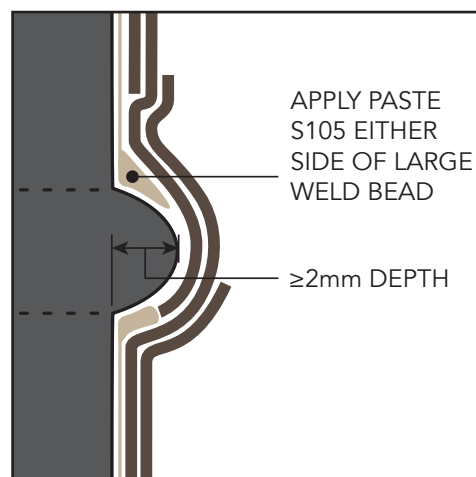

Fig. 3: Large weld beads.

MARINE PILING TAPE APPLICATION

The pile can be wrapped with Marine Piling Tape from the top down or the bottom up depending on access, tidal movement, or other restrictions at site.

The Marine Piling Tape shall be applied with the correct side facing the pile. This will mean that the backing film, which is not removed, is the side that faces away from the pile surface (see Fig. 4). The Marine Piling Tape, together with the Paste S105 forms the primary corrosion prevention layer. The Marine Piling Tape must be in contact with the surface of the pile at any point within the area for protection.

The wrapping shall start with 2 full circumferential wraps of the Marine Piling Tape (see Fig. 5). The wrapping shall then proceed spirally at a 55% overlap. The wrapping shall finish with 2 full circumferential wraps of the Marine Piling Tape. There shall be a minimum of 2 layers of Marine Piling Tape at any point in the area for protection.

If another SeaShield System shall be applied to the pile, the Marine Piling Tape shall extend onto the pile either:

- Fully, should the other SeaShield System be completely applied within the work shift;

OR

- Partially, to enable additional Marine Piling Tape to overlap a minimum of 100mm onto the existing Marine Piling Tape in a future work shift.

A new roll of Marine Piling Tape shall overlap onto the previous roll by the width of the roll. For example, if the roll is 300mm wide then the overlap shall be 300mm (see Fig. 4). The Marine Piling Tape shall be smoothed into position as it is wrapped around the pile.

It is recommended to minimise the amount of time the Marine Piling Tape is exposed to the marine environment. The Marine Piling Tape shall not be left exposed to the marine environment beyond the end of a work shift. Prolonged exposure of the Marine Piling Tape to the tidal, wind and wave conditions of the marine environment may result in damage to the Marine Piling Tape. Should the Marine Piling Tape be exposed to the marine environment for a prolonged length of time it shall be inspected for damage and any damage shall be repaired as described within the relevant Maintenance and Repair document.

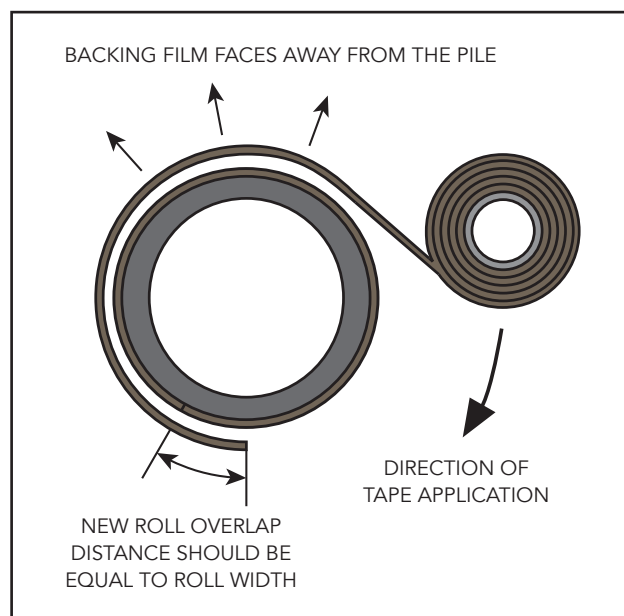

Fig. 4: Correct tape application procedure.

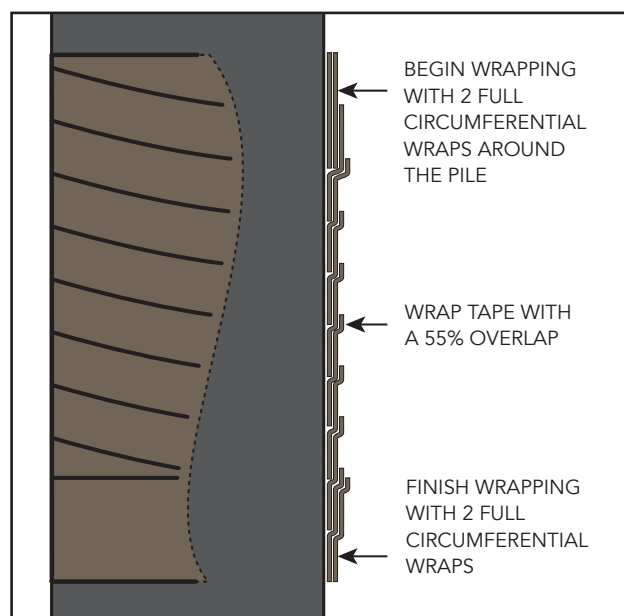

Fig. 5: Sectional view showing tape application and 55% overlap.

BITUMEN OUTERWRAP APPLICATION

The pile can be wrapped with Bitumen Outerwrap from the top down or the bottom up depending on access, tidal movement, or other restrictions at site. The Bitumen Outerwrap shall extend a minimum of 100mm beyond the ends of the Marine Piling Tape (see Fig. 7) unless the SeaShield 80 System shall be overlapped by or shall overlap onto another SeaShield System. In this instance the Marine Piling Tape must be continuous under both systems at a minimum of 2 layers.

The Bitumen Outerwrap is manufactured with an interleaving. This interleaving shall be removed during application (see Fig. 6). The interleaving shall be peeled back to expose approximately 100mm of the bitumen adhesive. The exposed adhesive shall be pressed firmly onto the pile surface and Marine Piling Tape to secure it in position.

The wrapping shall start with 2 full circumferential wraps of the Bitumen Outerwrap (see Fig. 7). The wrapping shall then proceed spirally at a 55% overlap. The wrapping shall finish with 2 full circumferential wraps of the Bitumen Outerwrap. There shall be a minimum of 2 layers of Bitumen Outerwrap at any point in the area for protection.

A new roll of Bitumen Outerwrap shall overlap onto the previous roll by the width of the roll. For example, if the roll is 300mm wide then the overlap shall be 300mm (see Fig. 6).

During wrapping the Bitumen Outerwrap shall be smoothed by hand to exclude water, air bubbles and wrinkles from under the tape. The Bitumen Outerwrap shall be inspected to ensure it has been wrapped with the specified 55% overlap, that large air bubbles (greater than 25mm across) are excluded from under the Bitumen Outerwrap and that all overlaps are sealed together.

Secure the end of the Bitumen Outerwrap by applying 4 circumferential wraps of PVC Self-Adhesive Tape.

If the SeaShield 80 System is applied in conjunction (on the same pile) with another SeaShield System, the Bitumen Outerwrap shall be overlapped onto the other SeaShield System or the other SeaShield System onto the Bitumen Outerwrap by 50mm.

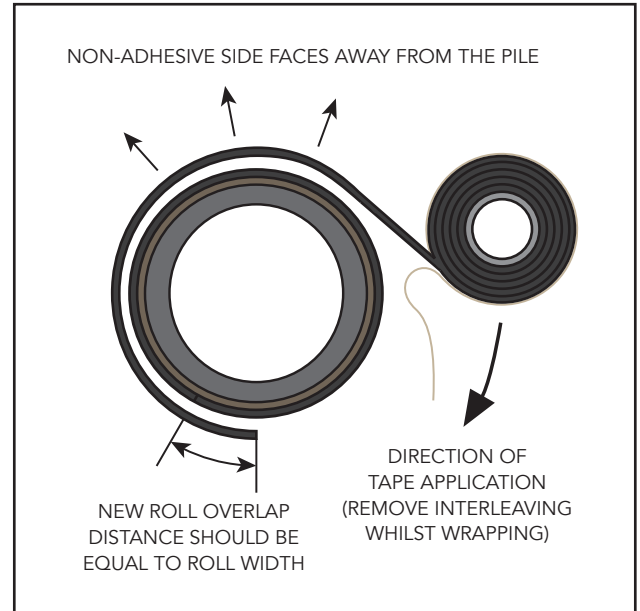

Fig. 6: Correct tape application procedure.

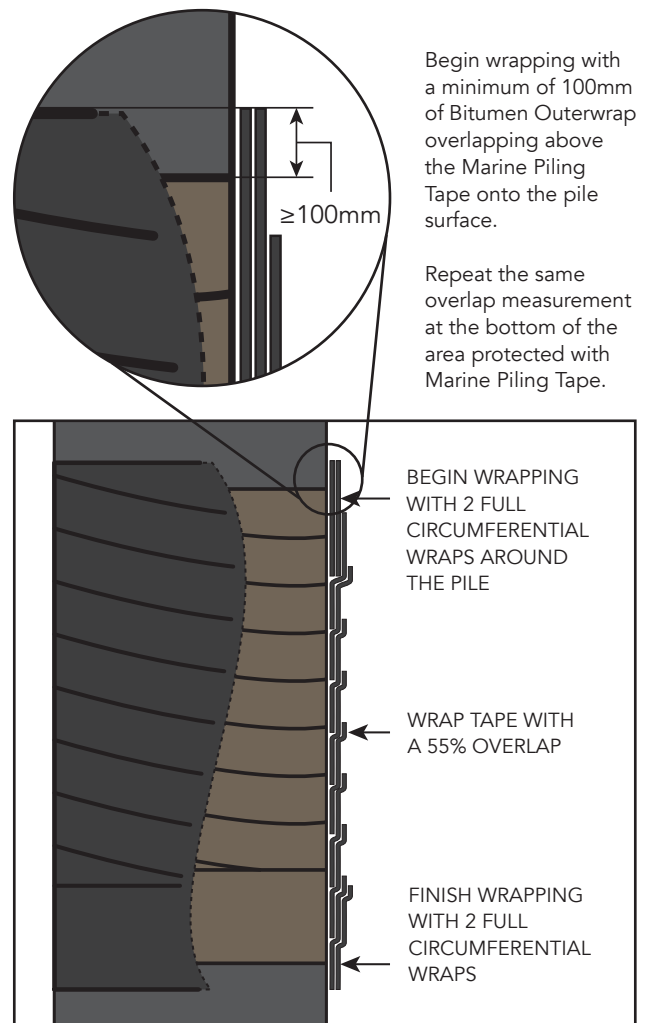

Fig. 7: Sectional view showing tape application and 55% overlap.