

HIGH PERFORMANCE CORROSION PREVENTION TAPES FOR ABOVE AND BELOW GROUND PIPELINES OFFERING EFFECTIVE PROTECTION FOR WELD JOINTS, FITTINGS AND FABRICATIONS.

INSTRUCTIONS FOR USE

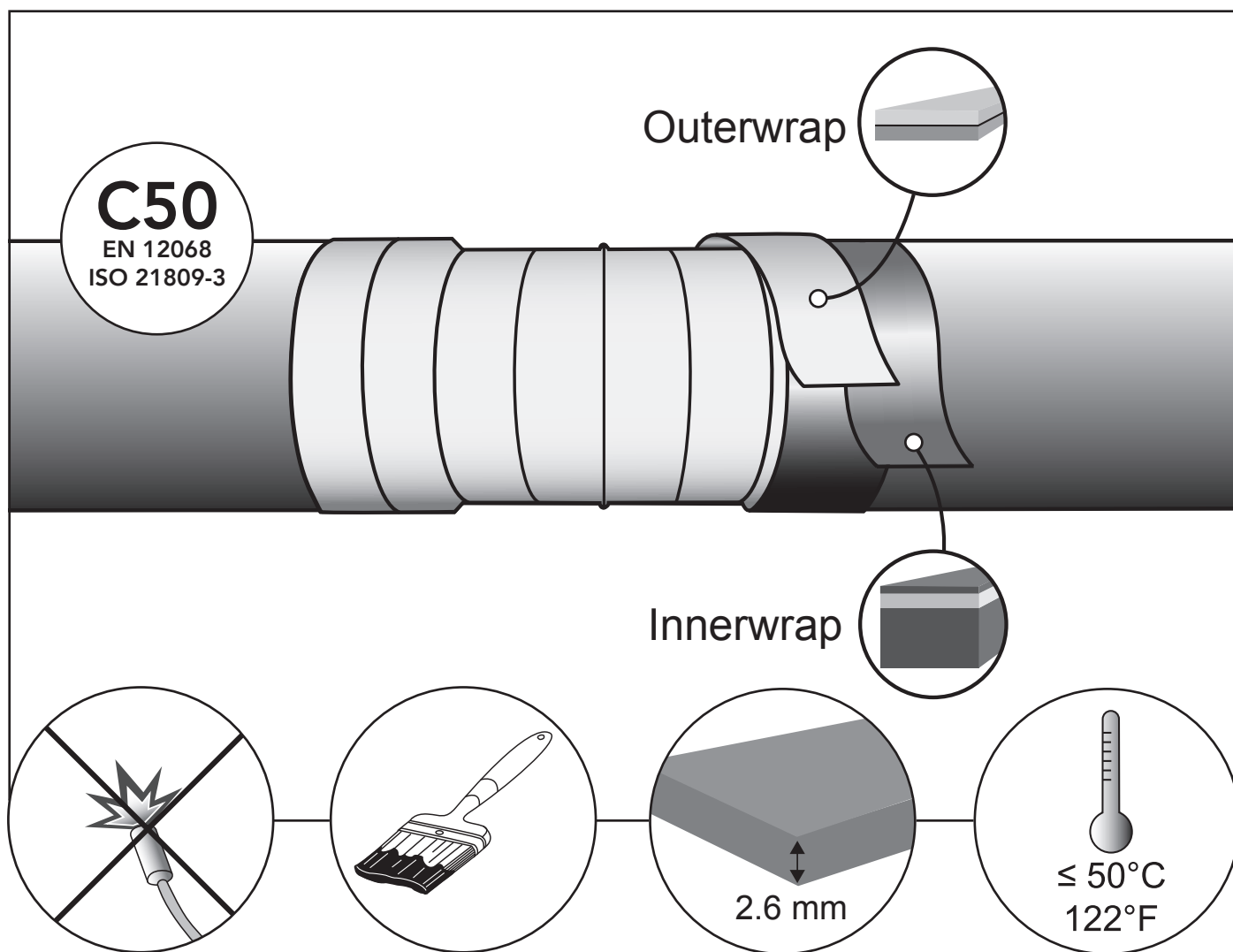

SYSTEM COMPONENTS

- PREMIER BUTYL P16HT™ PRIMER
- PREMIER BUTYL MASTIC™
- PREMIER BUTYL S43™ INNERWRAP
- PREMIER BUTYL R23™ OUTERWRAP

FEATURES

- Excellent adhesion
- Great flexibility provides extra protection for vulnerable areas
- Excellent conformability and consistent uniform thickness
- Can be applied easily, with no specialist equipment required
- Compatible with common pipe coatings
- Excellent resistance to cathodic disbonding

APPLICATION PROCEDURE - BEVEL / CLEAN

The edges of the adjacent coating shall be bevelled as shown.

Thoroughly clean the area of the welded joint and the adjacent coating. The area cleaned shall extend at least 100mm on to the adjacent coating.

The surface of the steel and adjacent coating shall be free from grease, oil, and dust.

If solvent cleaning is required this shall be carried out according to Steel Structure Painting Council SSPC SP 1 using approved solvent, emulsion or cleaning compound.

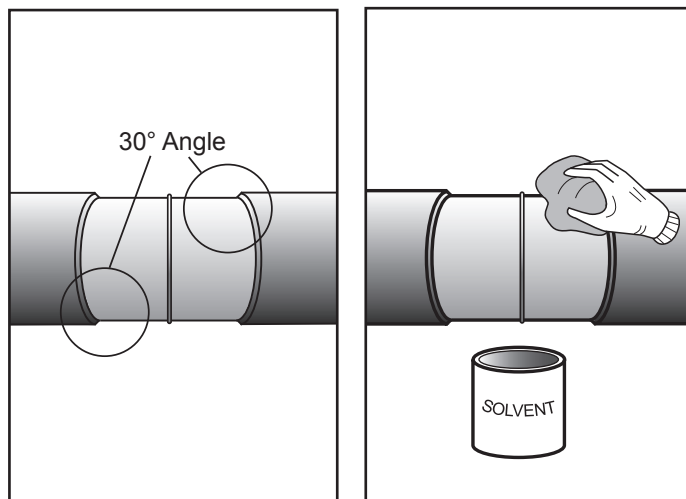

SURFACE PREPARATION

The preferred method of cleaning is Abrasive Blast Cleaning in accordance with one of the following standards:

Steel Structure Painting Council SSPC SP 10

Swedish Standard Institution SIS 05 59 00 Sa 21/2

International Standards Organization ISO 8501-1 Sa 21/2

An abrasive blast profile of 50 microns minimum is required. Clean the area of the welded joint and the adjacent coating. The area cleaned shall extend at least 100mm on to the adjacent coating.

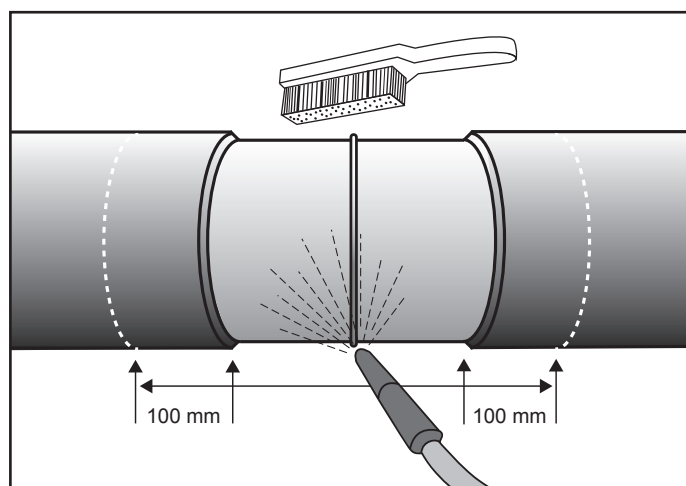

The following temperatures are to be respected:

Surface temperature: Min. 3°C over the dew point and $\geq 0^\circ\text{C}$ Max. 70°C.

Product temperature: Min. 3°C over the dew point and $\geq 10^\circ\text{C}$

PRIMING

Apply the primer to the dry and clean steel surface and approx. 100 mm of the adjacent factory coating on both sides. Drying time approx. 5-10 min, depending on the weather (test with finger).

Ensure there is adequate ventilation if applied in closed areas. If welded seams stick out considerably (in longitudinal or lateral direction) or if the junctions to the factory coating are not sufficiently chamfered, these sections are to be padded with mastic in order to prevent voids.

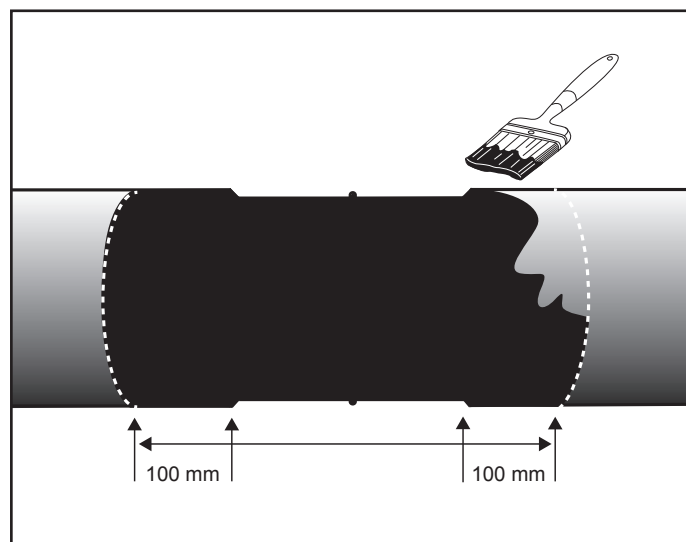

INNERWRAP APPLICATION

Select as wide a width of tape as practical, e.g. 100mm wide for 100mm diameter pipe. Peel back about 0.5m of interleaving and apply the 'grey' adhesive side of the tape firmly to the pipe, wrapping the tape spirally and ensuring correct alignment.

Maintain sufficient tension to ensure that the tape conforms to the surface without gaps. Repeat this, overlapping each turn by at least 25mm or preferably 55% to give double thickness. Start new roll by overlapping the ends by one tape width.

Note: Where longitudinal welds are included in the area to be wrapped, apply a 100mm wide strip of the tape longitudinally over the weld and press into the contours before wrapping.

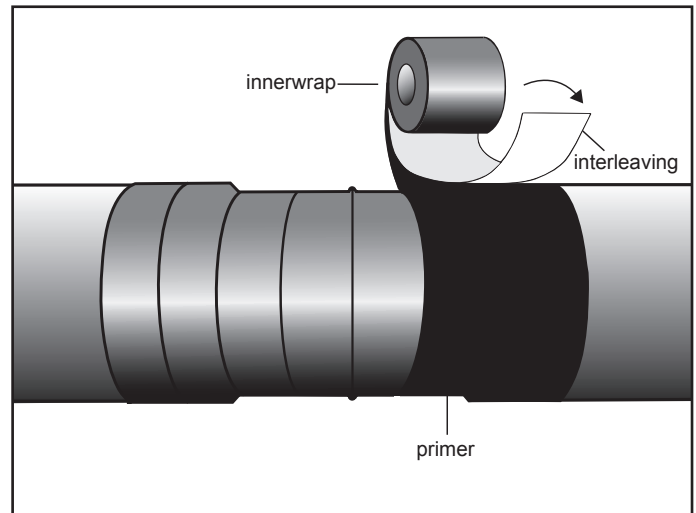

OUTERWRAP APPLICATION

Select as wide a width of tape as practical, e.g. 100mm wide for 100mm diameter pipe. Apply the adhesive side of the tape firmly to the pipe and commence wrapping the tape spirally, ensuring correct alignment.

Maintain sufficient tension to ensure that the tape conforms to the surface without gaps. Repeat this, overlapping each turn by at least 25mm or preferably 55% to give double thickness.

Start new roll by overlapping the ends by one tape width.

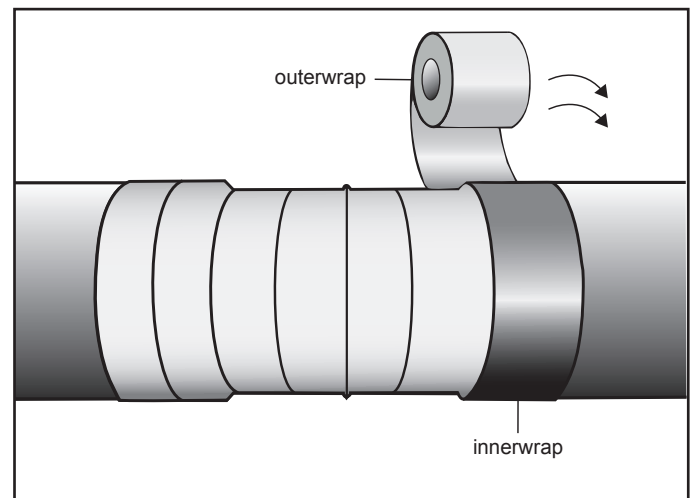

INSPECTION AND COATING REPAIR

Inspection:

Ensure that the entire surface is covered with no gaps or air pockets. Ensure that the correct overlap is achieved. Holiday test at 10kV

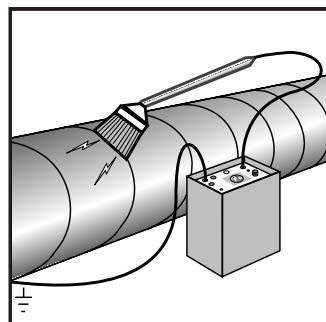
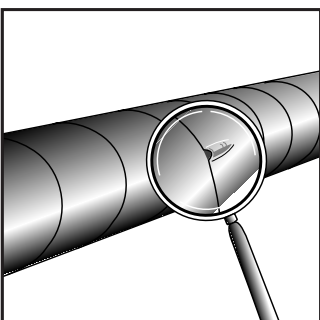

Coating Repairs:

1. Mechanical Damage:

Damaged coating should be repaired by first cleaning and removing any loose coating and then using Butyl Mastic to fill any voids to create a smooth surface. Then wrap Innerwrap Tape and Outerwrap Tape over the damaged area as described in sections 4 and 5 above, extending all around at least 50mm onto firm existing coating.

2. Peeling Test Damage:

To repair damage caused by a peeling test, first press the peeled section of tape firmly back into position then wrap the area with the Innerwrap and Outerwrap Tape as explained above under 'Mechanical Damage'.

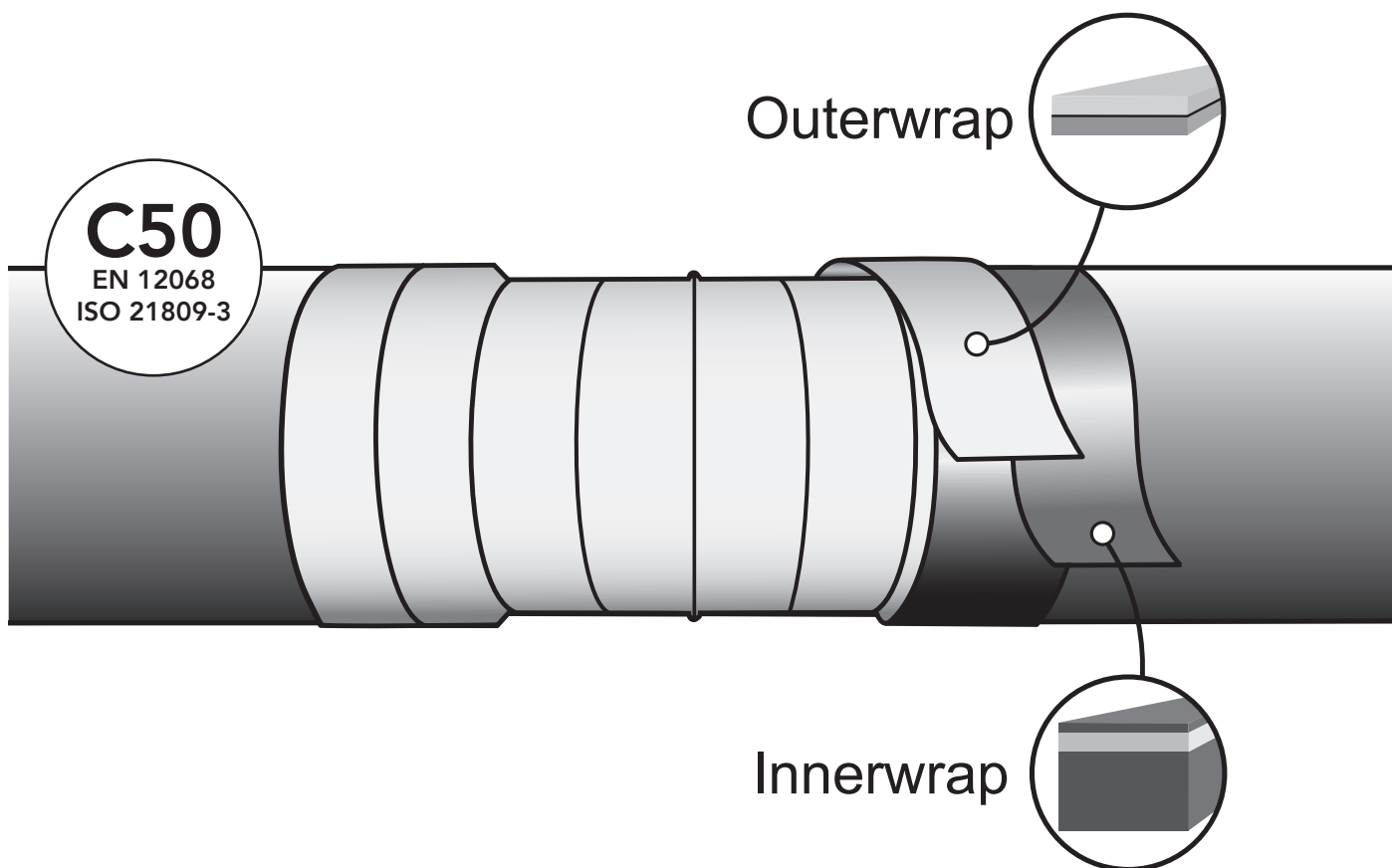

STORAGE

- Store correct way up in original packaging.
- Store away from heat and open flames.
- Do not store in direct sunlight.

HANDLING

- Do not get in eyes, on skin, or on clothing.
- Wash thoroughly after use and before work breaks to remove compound from the skin.
- Careful attention should be given to personal hygiene.
- Change and clean soiled clothing.

Please refer to Safety Data Sheets for full information.

DISPOSAL

Please minimise or avoid waste wherever possible. Please do not discard waste material, including packaging, in the surrounding environment. Follow all relevant legislation for disposal.