

INSTRUCTIONS FOR USE

EQUIPMENT

- Personal Protection Equipment (not supplied by SeaShield)
- Surface Preparation Equipment (not supplied by SeaShield)
- Sockets and/or spanners - 19mm (not supplied by SeaShield)
- Cutting tool (not supplied by SeaShield)
- Denso Paste S105™
- SeaShield™ Marine Piling Tape
- Densyl™ Mastic or Densyl™ Mastic Blankets (as required)
- SeaShield 2000FD™ Jackets of the correct size
- SeaShield 2000FD™ Nuts, Bolts and Washers
- SeaShield 2000FD™ Clamping Tools
- Impact Wrench rated to 550 Nm (400 ft-lb) torque (not supplied by SeaShield)
- Imperial Socket, ½-Inch Square Drive & ½-Inch A/F (not supplied by SeaShield)

HANDLING AND STORAGE

- All materials shall be stored upright in their original packaging, out of direct sunlight.
- All materials other than SeaShield Jackets shall be stored in a cool dry place between 5°C and 35°C.
- SeaShield 2000FD Jackets shall be handled with care to avoid damage to the jacket. They shall remain rolled and taped to prevent damage for transportation to the installation site.
- SeaShield 2000FD nuts, bolts and washers shall be kept away from contamination such as dust and dirt.
- All tools shall be stored in their original packaging, in a cool dry place out of direct sunlight between 5°C and 35°C.
- Please read the Safety Data Sheet for all materials before commencing application.

DISPOSAL

Please minimise or avoid waste wherever possible. Please do not discard waste material, including packaging, in the surrounding environment. Follow all relevant legislation for disposal.

IMPORTANT:

Winn & Coales (Denso) Ltd pursue a policy to develop and continually improve all of our products and therefore information given in this data sheet is intended as a general guide and does not constitute a warranty, specification or risk assessment. These guidelines may not cover all circumstances; however, our sales personnel are committed to assisting the user in establishing the suitability of the product for its intended purpose and additional specific information, including Safety Data Sheets, is available on request. We recommend that installation is carried out with due regard to Health and Safety and in accordance with relevant local statutes and regulations. Any conflict between these guidelines and the specific project specifications must be resolved by the user before work commences. All rights reserved.

CORROSION CONTROL FOR JETTY PILES & MARINE STRUCTURES**SURFACE PREPARATION****METHODS AND EQUIPMENT**

The following methods may be used:

- Hand tool cleaning.
- Power tool cleaning.
- High pressure water jetting.
- Abrasive blast cleaning.
- Other methods by agreement.

The following shall be considered:

- The degree of marine growth on the pile or bracing.
- The degree of corrosion on the pile or bracing.
- Any existing corrosion prevention coatings on the pile or bracing.
- Any hot working or spark restrictions at the site.
- Any environmental restrictions at the site.
- The reduction of debris being deposited into the marine environment.
- Any other considerations specific to the site.

DEGREE OF CLEANING**Metal:**

- All loose corrosion products must be removed.
- All mill scale must be removed.
- Protrusions must be ground smooth to remove sharp edges and sudden changes of profile. Care shall be taken to avoid damage to the weld seam.

Concrete:

- All loose concrete must be removed.
- All concrete laitance must be removed.
- Protrusions must be ground smooth to remove sharp edges and sudden changes of profile.

Timber:

- All loose timber must be removed.
- Protrusions must be ground smooth to remove sharp edges and sudden changes of profile.

Existing corrosion prevention coatings:

- All loose corrosion prevention coatings must be removed.
- Tightly adhering corrosion prevention coatings can remain on the surface of the pile.

Marine growth:

All living marine growth must be removed. Marine biofilm can establish on the surface of a pile within 24 hours. Groups of piles may have heavy levels of marine growth and other contamination removed as a "batch". If that "batch" of piles are then not wrapped with a SeaShield system within 24 hours, it is required as a minimum to wire brush the surface of the pile to remove any biofilm that may have formed.

Non-living, tightly adhering mineral deposits caused by shellfish or similar can remain on the surface of the pile.

The surface of the pile can be washed with seawater as required to aid in achieving the above requirements.



Example image of an acceptable level of surface preparation.

CORROSION CONTROL FOR JETTY PILES & MARINE STRUCTURES



Example image of a pile featuring loose corrosion that would require removal.



Example image of a pile featuring a loosely adhering corrosion prevention coating that would require removal.



Example image showing tightly adhering corrosion prevention coating and corrosion (orange rust) that would **not** require removal.

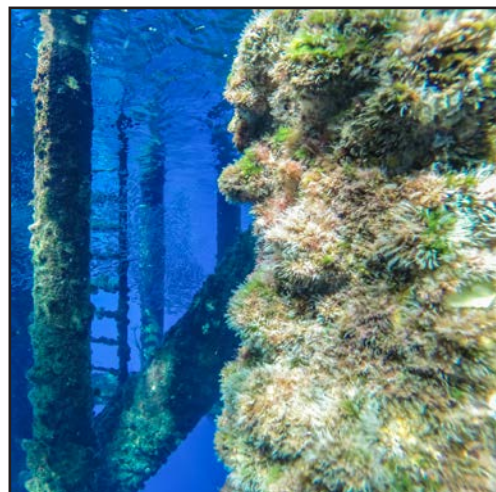

Example image of marine growth.



Example image of marine biofilm.



Example image of a pile featuring acceptable levels of non-living, tightly adhering mineral deposits.

PASTE S105 APPLICATION**DEEP PITS**

A deep pit is defined as a pit of 2.0mm or greater, where there is a risk that the Marine Piling Tape will 'bridge' the pit, creating a void. These pits shall be filled with Paste S105 to prevent there being a void (see Fig. 1).

Should there be a very deep pit, or should it be otherwise difficult to fill a deep pit with Paste S105, a thin film of Paste S105 shall be applied into the pit followed by a patch of Marine Piling Tape which shall be pressed firmly into the pit to prevent there being a void (see Fig. 2).

Paste S105 can be applied by various means to fill deep pits such as, flexible filling knife, trowel, gloved hand, roller, brush, or other means as agreed.

LARGE WELD BEAD

A large weld bead is defined as a weld bead of 2.0mm height or greater, where there is a risk that the Marine Piling Tape will 'bridge' the weld bead, creating a void.

Paste S105 shall be applied along either side of a weld bead, to prevent there being a void (see Fig. 3).

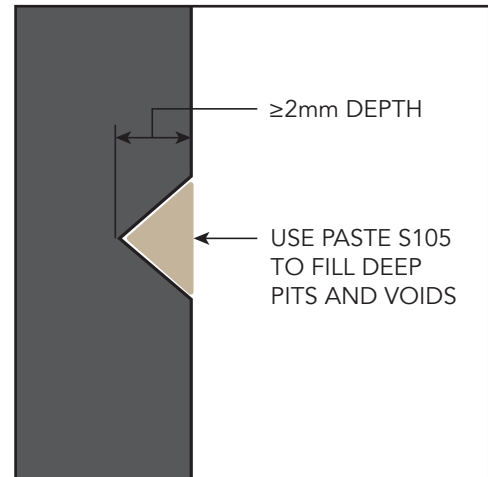

Fig. 1: Filling deep pits of 2.0mm, or greater, depth.

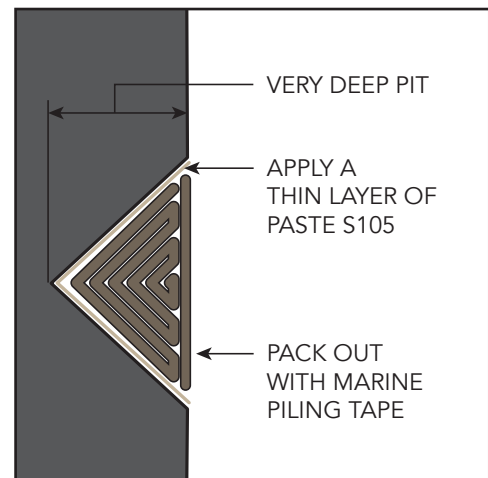

Fig. 2: Filling very deep pits.

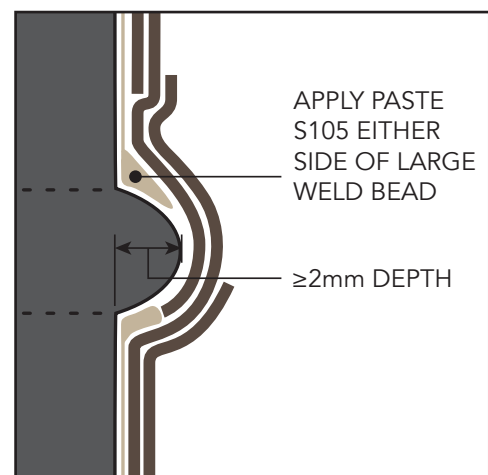

Fig. 3: Large weld beads.

CORROSION CONTROL FOR JETTY PILES & MARINE STRUCTURES

MARINE PILING TAPE APPLICATION

The pile can be wrapped with Marine Piling Tape from the top down or the bottom up depending on access, tidal movement, or other restrictions at site.

The Marine Piling Tape shall be applied with the correct side facing the pile. This will mean that the backing film, which is not removed, is the side that faces away from the pile surface (see Fig. 4). The Marine Piling Tape, together with the Paste S105 forms the primary corrosion prevention layer. The Marine Piling Tape must be in contact with the surface of the pile at any point within the area for protection.

The wrapping shall start with 2 full circumferential wraps of the Marine Piling Tape (see Fig. 5). The wrapping shall then proceed spirally at a 55% overlap. The wrapping shall finish with 2 full circumferential wraps of the Marine Piling Tape. There shall be a minimum of 2 layers of Marine Piling Tape at any point in the area for protection.

If another SeaShield System shall be applied to the pile, the Marine Piling Tape shall extend onto the pile either:

- Fully, should the other SeaShield System be completely applied within the work shift;

OR

- Partially, to enable additional Marine Piling Tape to overlap a minimum of 100mm onto the existing Marine Piling Tape in a future work shift.

A new roll of Marine Piling Tape shall overlap onto the previous roll by the width of the roll. For example, if the roll is 300mm wide then the overlap shall be 300mm (see Fig. 4). The Marine Piling Tape shall be smoothed into position as it is wrapped around the pile.

It is recommended to minimise the amount of time the Marine Piling Tape is exposed to the marine environment. The Marine Piling Tape shall not be left exposed to the marine environment beyond the end of a work shift. Prolonged exposure of the Marine Piling Tape to the tidal, wind and wave conditions of the marine environment may result in damage to the Marine Piling Tape. Should the Marine Piling Tape be exposed to the marine environment for a prolonged length of time it shall be inspected for damage and any damage shall be repaired as described within the relevant Maintenance and Repair document.

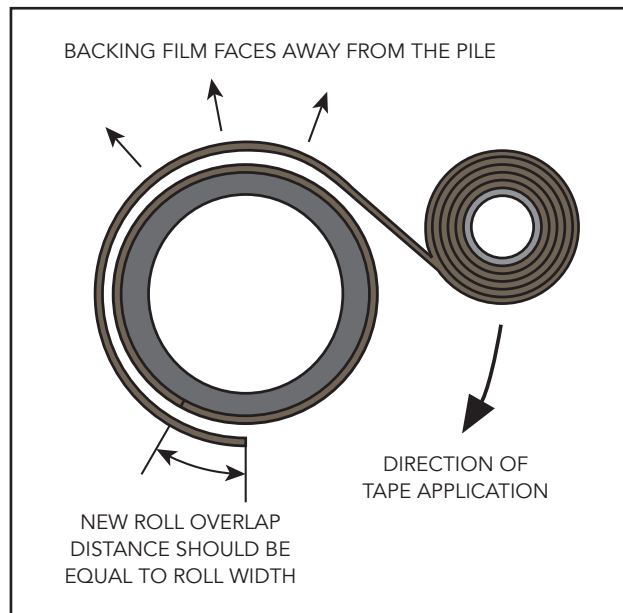

Fig. 4: Correct tape application procedure.

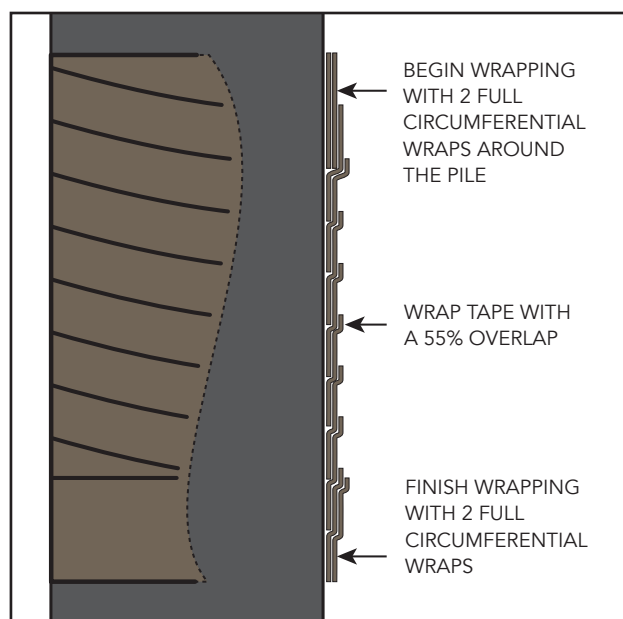

Fig. 5: Sectional view showing tape application and 55% overlap.

HDPE JACKET APPLICATION

The jacket shall be manufactured to have length of HDPE where the jacket can overlap onto. This length of HDPE shall be lubricated with Paste S105 (see Fig. 6).

The jacket shall be positioned so that the bolting bars are situated on the opposite side of the pile to the prevailing weather conditions. If multiple jackets per pile are to be installed, they may be installed from the top jacket downward or from the bottom jacket upwards. The 50mm overlap shall be positioned to allow the remaining jackets to cover the 50mm overlap.

The bolting holes shall be aligned to allow insertion of the Clamping Rods. There are 12 bolting holes in a 1.9m height jacket. Three Clamping Tools are required to fit a 1.9m height jacket. The Clamping Tools shall be spaced as indicated in the diagram below so that there is an empty bolting hole above and below each Clamping Tool (see Fig. 7).

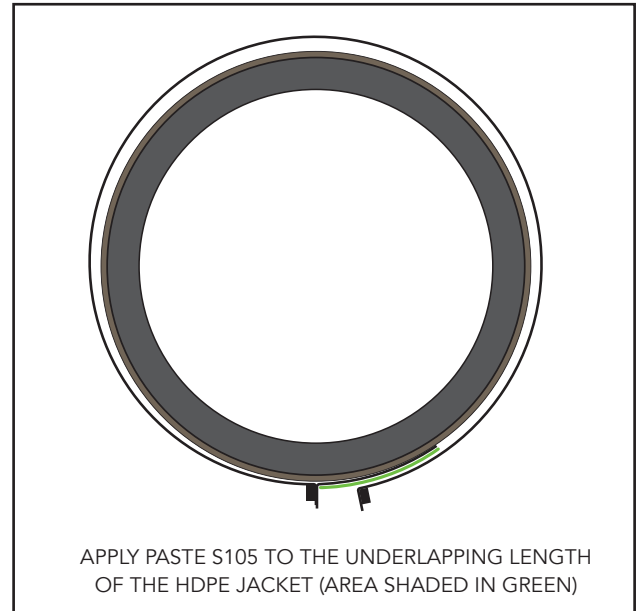

Fig. 6: The HDPE jacket (featuring overlapping length of HDPE) is positioned around the pile that has been pre-wrapped with Marine Piling Tape.

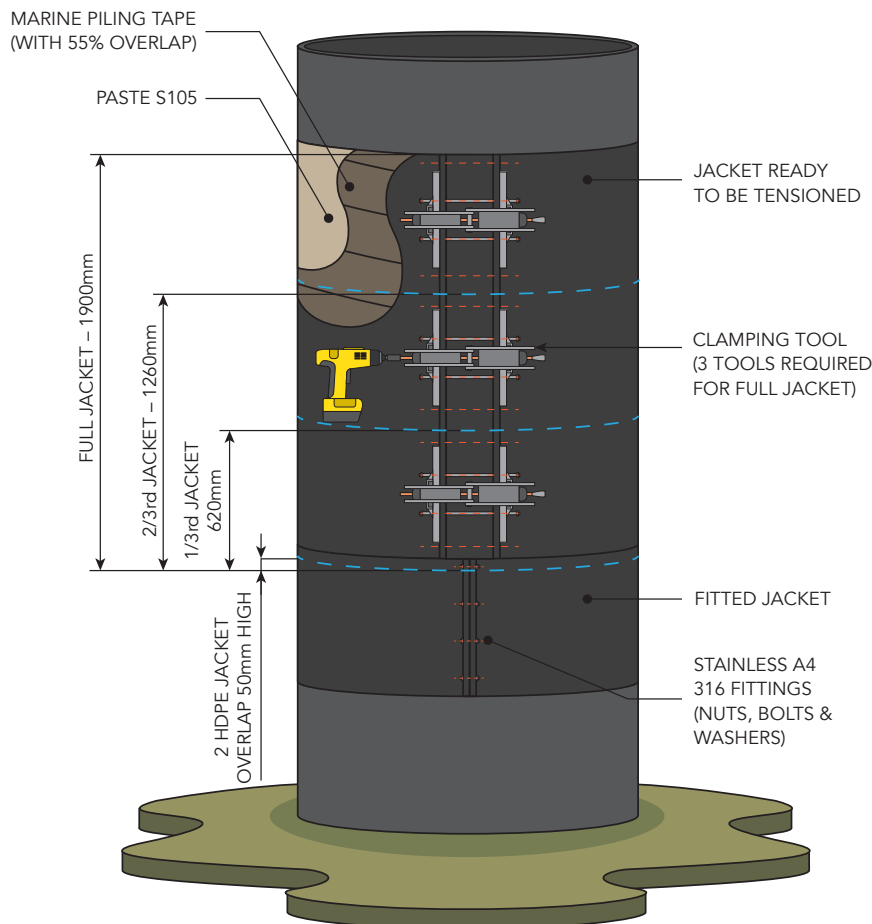

Fig. 7: Correct jacket application, with cutaways showing sub-layers of Paste S105 and Marine Piling Tape.

CORROSION CONTROL FOR JETTY PILES & MARINE STRUCTURES

The Clamping Rods shall pass through one of the Clamping Bars first. They shall then pass through both bolting bars before passing through the other Clamping Bar. The Clamping Rods shall be secured using either the M12 nuts or the retaining clip depending on the design of the Clamping Rod.

It is recommended to fit the middle Clamping Tool first. This Clamping Tool may be partially tensioned to hold the jacket in position while the additional Clamping Tools are positioned. The Clamping Tools shall be tensioned evenly and as much as reasonably possible, simultaneously until the bolting bars are brought completely together. The Clamping Tools have the drive direction indicated on their surface by way of a circular arrow. Note that the drive direction for the Clamping Tool is opposite on each side of the Clamping Tool.

Once the bolting bars have been brought fully together the M12 fasteners shall be fitted into the bolting holes that are not occupied by the Clamping Tools. The M12 fasteners shall be tightened in accordance with the Bolt Tensioning Diagram (see Fig. 8).

The Clamping Tools shall now be removed. The M12 fasteners shall be fitted to the bolting holes that were occupied by the Clamping Tools. These M12 fasteners shall also be tightened in accordance with the Bolt Tensioning Diagram.

Should there be any exposed tape above or below the jacket or series of stacked jackets, it shall be trimmed as close to the end jacket as possible (see Fig. 9).

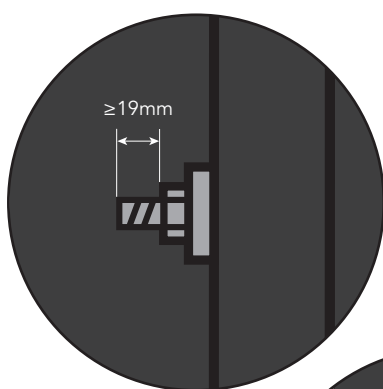

Fig. 8: Ensure a minimum of 19mm of exposed thread on each bolt.

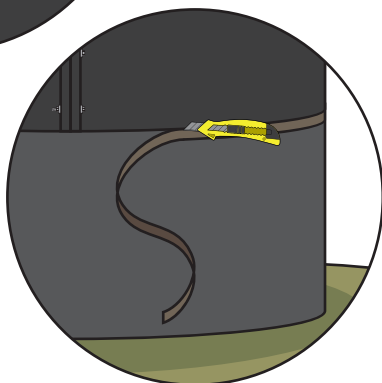

Fig. 9: Trim any exposed tape at the top and bottom of the jacket (or series of jackets).

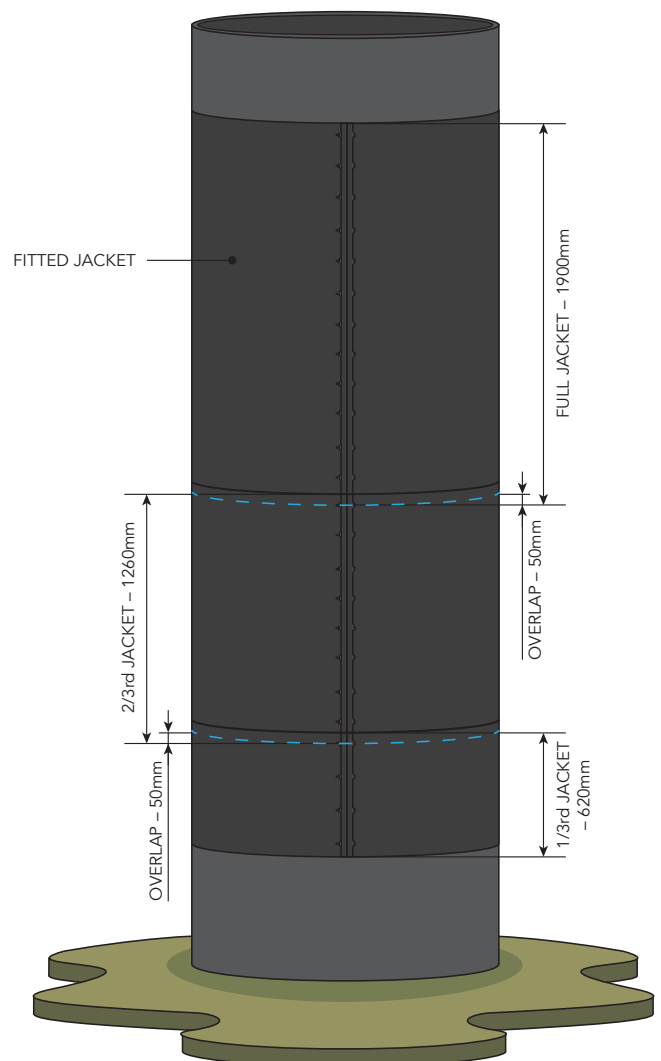

Fig. 10: Completed jacket application.