

# DENSO Skid Resistant OVERBANDING TAPE

## INSTRUCTIONS FOR USE

Publication Number  
388-3-2003

### Description:

A polymer modified bituminous strip for use as an instant waterproof adhesive seal over cracks or failed reinstatement joints (up to 5-mm wide) on road pavements on secondary roads. The application of the overbanding tape prevents the ingress of water which causes cracking and severe fretting leading to the eventual breakdown of the asphalt pavement. A coating of particles is present on the upper surface of the overbanding tape, which enhances skid resistance.

### Key Points:

- Minimum air temperature 8°C.
- Minimum road surface temperature 8°C.
- Dry road surface essential, must be free from salt residues, oily contamination, dirt and debris.
- Maximum crack width 5mm.
- Pre-heat road surface
- To improve adhesion apply Densoband Primer
- Roll firmly into place

### Surface Preparation:

Remove dirt and debris from the crack area and surrounding pavement surface (as Fig 1). Ensure that the road surface is dry. If necessary use a gas burner to dry the crack and the surrounding area. The road surface may be pre-heated immediately prior to application of the overbanding tape to ensure that a secure bond is rapidly formed. Do NOT apply gas burner to the surface of the tape itself. For improved adhesion of the tape, Densoband Primer can be applied to the joint area prior to application.

### Application:

Apply Denso Skid Resistant Overbanding Tape by hand or by using the application roller following the line of the crack. The tape is applied with the textured side up. The interleaving is removed as the application progresses. Traffic may flow immediately.

### Application by hand:

Recommended for small cracks and patches or where abrupt changes in direction occur. Peel back the interleaving and apply the tape over the crack. Use a hand held roller to press the tape down thoroughly and to ensure full contact with the road surface. At joints and at corner details overlap the tape by at least 30mm, immediately trim back any surplus material using a safety knife and securely roller or tamp into position.

### Application by Denso Roller 75 Applicator:

Fit the roll of tape onto the roll holder (as Fig 3) and screw the knurled nut clockwise to secure the roll in place.

Peel back the interleaving film from the end of the roll and unwind it for one turn to expose the bitumen compound

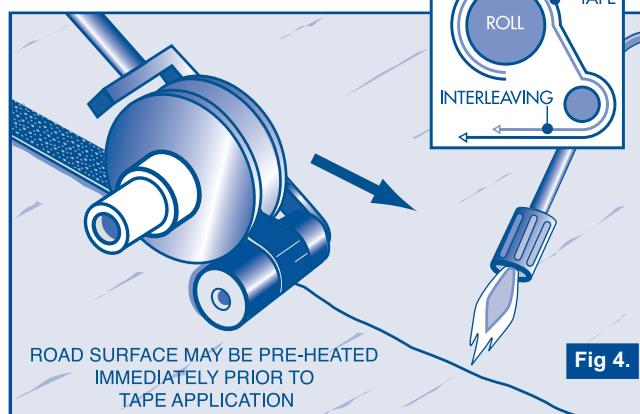
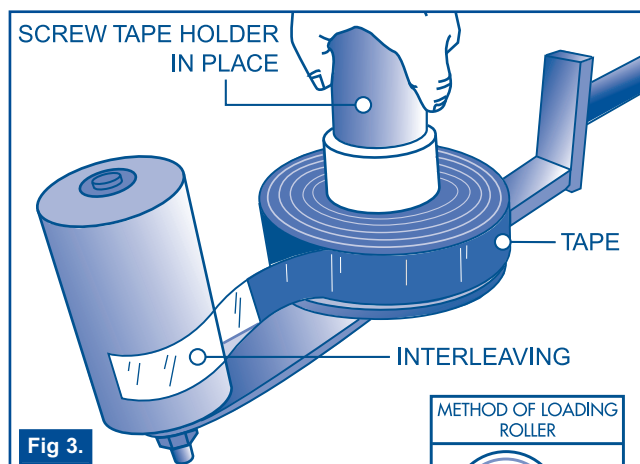
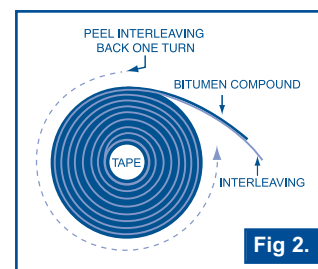
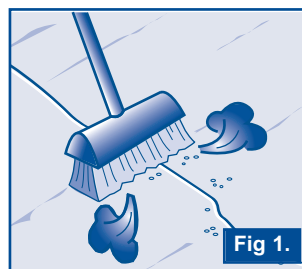

(as Fig 2). Pass the tape around the application roller (as Fig 3). Push the roller along the line of the crack as shown (as Fig 4) to apply the tape centrally over the crack. Press the tape down thoroughly and remove the interleaving. Traffic may flow immediately.

**Storage:** Store in cool, dry conditions. In cold weather conditions application will be assisted by storing tape overnight at room temperature.

**Safety:** Safety Data Sheets giving full information are available.

