

INSTRUCTIONS FOR USE

Densopol™ Tapes for the long-term protection of buried or immersed pipes, welded joints, bends, fittings and similar structures from corrosion.

To protect the metal structure from the environment the tape must cover the entire surface.

EQUIPMENT

- Hand wire brush / power tool / blast cleaning equipment (optional).
- Brush, brush cleaning solvent.
- Utility knife and Holiday Detector (optional).
- PPE must be worn in accordance with the manufacturer's recommendations as set out in the Safety Data Sheets.

SURFACE PREPARATION

Surfaces must be clean, dry and free from grease. Remove all loose rust, scale and flaking coatings by wire brushing to ISO 8501-1 St 3 or abrasive blast clean to ISO 8501-1 Sa 2½.

APPLICATION PROCEDURE

Diagram of correct application procedure:

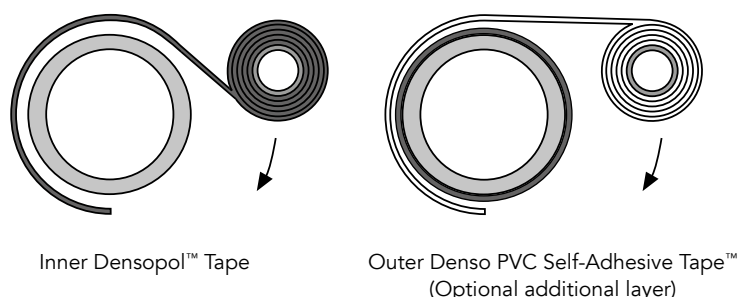

1. PRIMING

Brush apply one coat of Denso Primer D™ over the entire area to be wrapped. Allow to dry for 20 minutes or until touch dry.

Coverage:	9-11m ² /l
Wet film thickness:	90-110 microns
Dry film thickness:	40-50 microns
Drying time:	Approx. 20 minutes

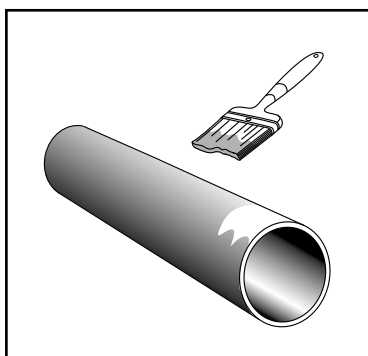

Fig. 1: Priming pipes, rods and cables. Apply Denso Primer D to entire area to be wrapped with tape.

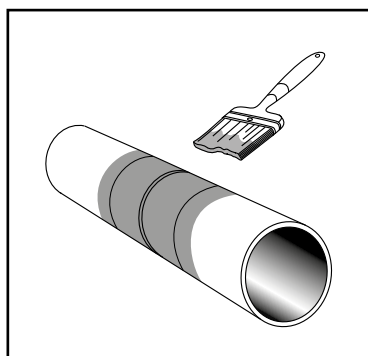

Fig. 2: Priming butt welded joints. Apply Denso Primer D to entire area to be wrapped with tape.

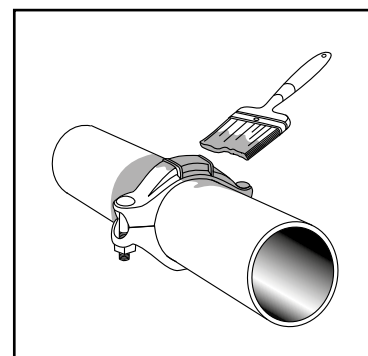

Fig. 3: Priming flanges and couplings. Apply Denso Primer D to entire area to be wrapped with tape.

2. APPLICATION

A) PIPES, RODS AND CABLES

Select as wide a width of tape as practical, e.g. 100mm wide for 150mm diameter pipe. Peel back about 0.5m of interleaving and apply the adhesive side of the tape firmly to the pipe. Unroll the tape about 0.5m, peel back the interleaving and wrap the tape spirally ensuring correct alignment. Maintain sufficient tension to ensure that the tape conforms to the surface without gaps. Repeat this, overlapping each turn by 55% to give double thickness. Start a new roll by overlapping the ends by one tape width. An optional additional layer of Denso™ PVC Self-Adhesive Tape can be added for an extra layer of mechanical and UV protection.

NOTE: Where longitudinal welds are included in the area to be wrapped, apply a 100mm wide strip of the tape longitudinally over the weld and press into the contours before wrapping.

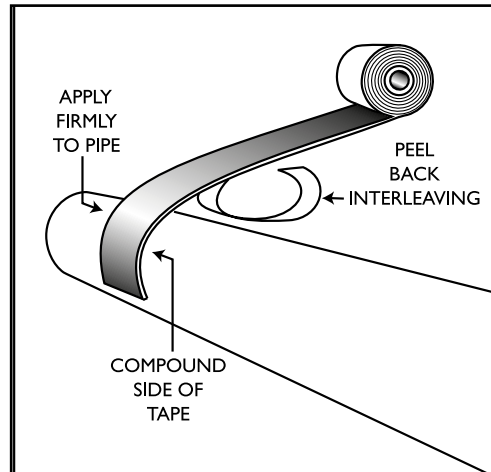

Fig. 4: Starting the first roll of tape.

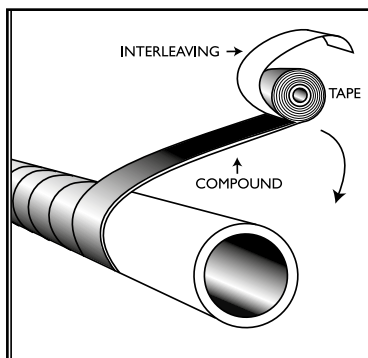

Fig. 5: Diagram showing the correct application procedure for wrapping tape.

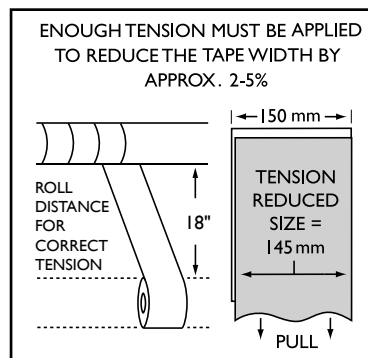

Fig. 6: Ensure that tape is applied with the correct amount of tension to reduce width as shown in illustration above.

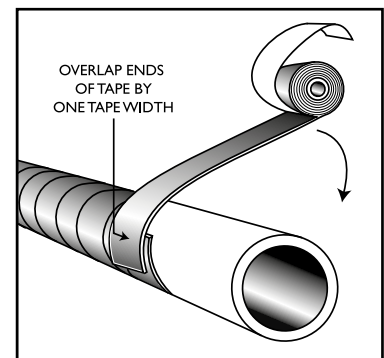

Fig. 7: Starting a new roll of tape.

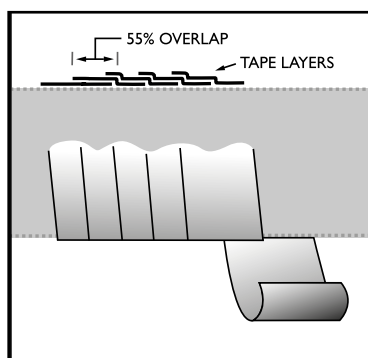

Fig. 8: Overlapping each turn by 55% gives a double thickness.

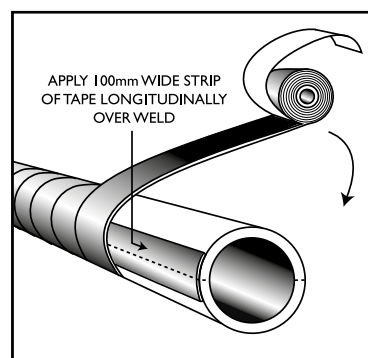

Fig. 9: Wrapping a longitudinal weld.

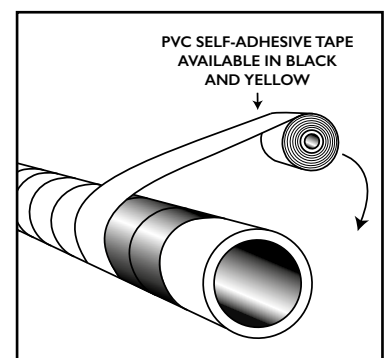

Fig. 10: Apply an optional outerwrap of Denso PVC Self-Adhesive Tape with 55% overlap, beginning and ending the wrap with two full circumferential turns.

DENSOPOL 60™ & DENSOPOL 80™ (INCLUDING TROPICAL VERSIONS)

B) BUTT WELDED JOINTS

Finish as **(A)** but start and finish wrapping with a minimum of 75mm overlap on to the existing pipe coating either side of the joint area.

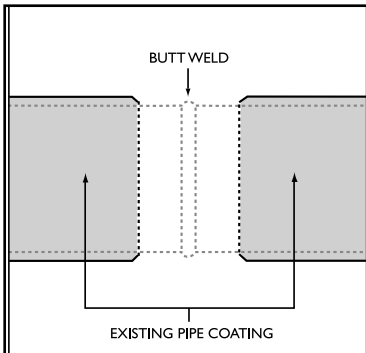

Fig. 11: Butt weld and existing coating ready for overwrapping with tape. Note cutback of coating can be 75mm - 150mm either side of the weld except on FBE coated pipe.

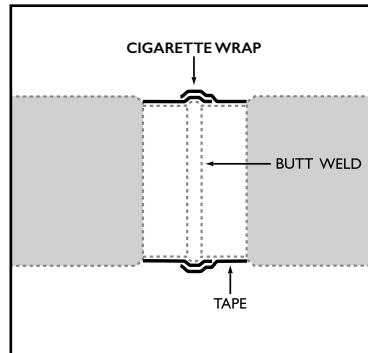

Fig. 12: If the factory coating is 3LPE, the typical thickness can be between 2.5mm to 5mm. It is therefore important to chamfer the edge of the 3LPE to 35°. Denso Primer D should be applied to the entire joint and onto the 3LPE by at least 75mm. Densopol Tape should then be applied using a cigarette method to completely cover the joint and factory cutback. The ends of the cigarette wrap should overlap by the same distance as the width of the tape being used.

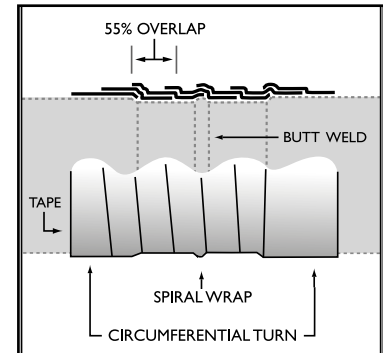

Fig. 13: Note method of wrapping.
 1. Start with one circumferential turn onto factory coating.
 2. Then change to spiral wrap with 55% overlap over weld area.
 3. Finish with one circumferential turn over factory coating the opposite side of the weld. Overlap tape at least 75mm onto existing coating.
 4. Circumferential wrap of Denso PVC Self-Adhesive Tape can be added, as **(A)**.

C) FLANGES, COUPLINGS AND VALVES

Profile the pipe joint with Densyl™ Mastic or Denso™ Profiling Mastic so that there will be no air gaps under the subsequent tape wrapping. Push the mastic firmly into all cavities and around all bolt heads, building it up to form a smooth profile suitable for wrapping – without forming bridges or voids.

Start the tape on the centre of the crown of the joint and wrap away from the centre, towards the adjoining pipe, overlapping each turn by 55% to give double thickness. Select a narrow width tape for this. Finish with at least one circumferential wrap onto the pipe to conclude first half of the application.

On the crown of the joint, start a new roll by overlapping the ends of tape by one tape width. Wrap towards the pipe on the opposite side of the joint, overlapping the tape by 55%. Smooth finished wrap down well – particularly at the tape edges.

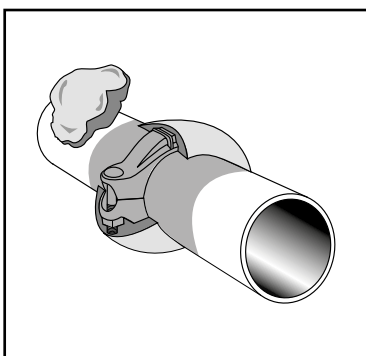

Fig. 14: Profiling the joint.

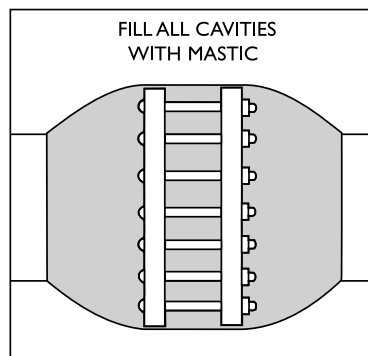

Fig. 15: Make sure that the mastic is pushed into all crevices and that it forms a smooth profile for wrapping.

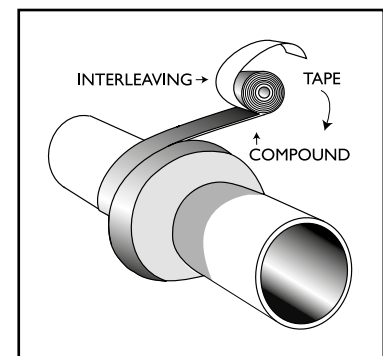

Fig. 16: Wrap joint in two halves. Start on crown and work towards pipe, then repeat from crown working towards pipe on opposite side of joint.

DENSOPOL 60™ & DENSOPOL 80™ (INCLUDING TROPICAL VERSIONS)**D) DAMAGED COATINGS**

Either cut a circumferential band of the damaged coating and treat as for Butt Welded Joints or cut away and remove loose coating from the damaged area and smooth or chamfer edges. Prime the exposed metal and a circumferential band extending 75mm either side of the damage. Build up the damaged area with patches of tape or Densyl Mastic. Wrap the section of pipe as for Butt Welded Joints.

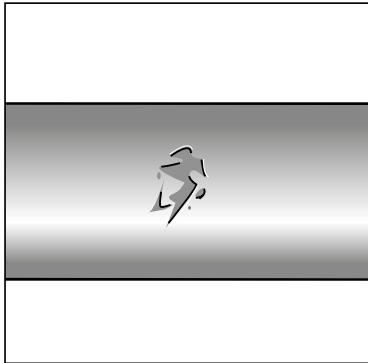

Fig. 17: Damaged pipe coating.

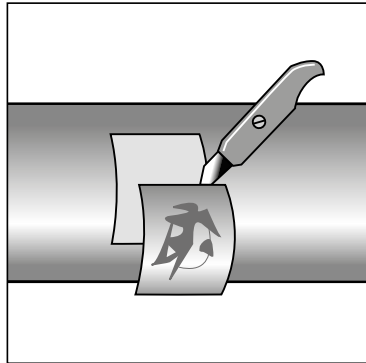

Fig. 18: Remove loose or damaged area then clean thoroughly.

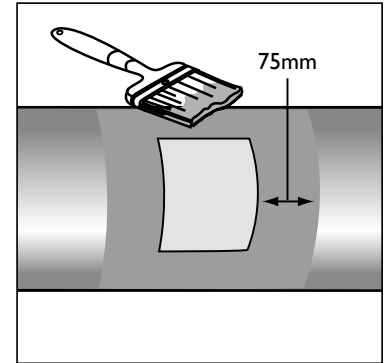

Fig. 19: Smooth edges and prime area at least 75mm onto sound coating.

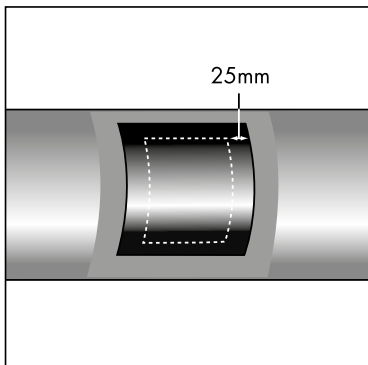

Fig. 20: Repair damaged area with a patch of tape overlapping at least 25mm onto primed sound coating area before wrapping with tape as (B).

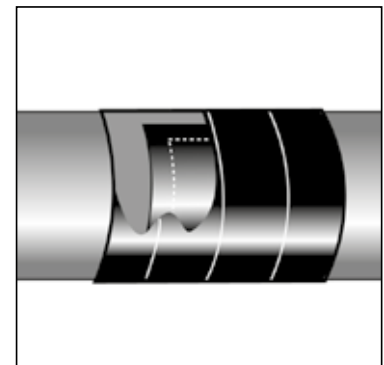

Fig. 21: Overwrap repair as (B).

3. INSPECTION

Ensure that the entire surface is covered with no gaps or air pockets. Examine adhesion by coupon test 24 hours after wrapping. Perform a holiday test using the correct voltages according to the tape and number of layers used (refer to the table on the following page).

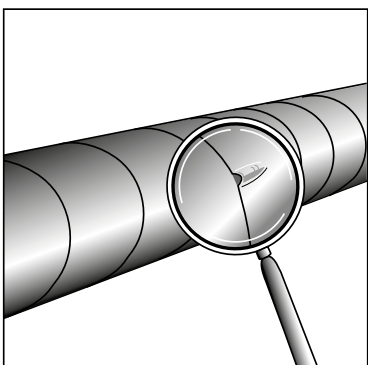

Fig. 22: Examine for gaps or air pockets (see repair procedure Figs. 17 to 21).

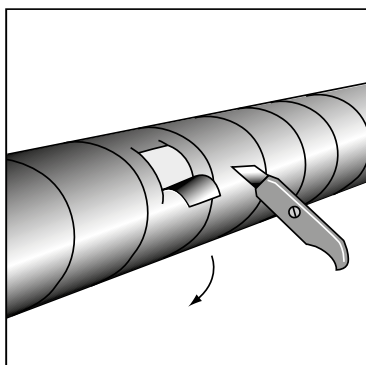

Fig. 23: Adhesion can be tested by pulling/removing a 50mm wide coupon of tape from the surface.

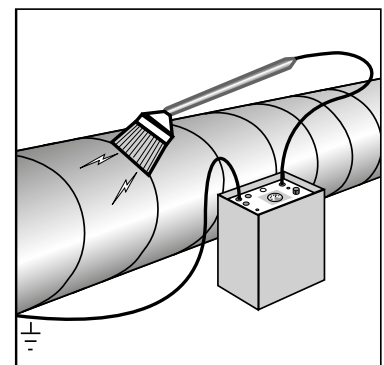

Fig. 24: Perform a holiday test using a ring or brass brush (refer to the table for holiday detection voltages).

APPLICATION TEMPERATURES & HOLIDAY DETECTION VOLTAGES

For ease of application, avoid using tape stored under very cold conditions.

		APPLICATION TEMPERATURE		HOLIDAY DETECTION VOLTAGE	
		MINIMUM	MAXIMUM	1 LAYER	2 LAYER
STANDARD	Densopol 60™	+5°C	+45°C	10 kV	15 kV
	Densopol 80™	+5°C	+45°C	10 kV	15 kV
TROPICAL	Densopol 60 HT™	+15°C	+50°C	10 kV	15 kV
	Densopol 80 HT™	+18°C	+50°C	10 kV	15 kV

STORAGE

- Store correct way up in original packaging.
- Store away from heat and open flames.
- Do not store in direct sunlight.
- In cold conditions, tape may need to be warmed to comply with minimum application temperatures (see above).

- Standard Grades store between: +5°C and +20°C
- Tropical Grades store between: +5°C and +35°C

HANDLING

- Do not get in eyes, on skin, or on clothing.
- Wash thoroughly after use and before work breaks to remove compound from the skin.
- Careful attention should be given to personal hygiene.
- Change and clean soiled clothing.

Please refer to Safety Data Sheets for full information.

DISPOSAL

Please minimise or avoid waste wherever possible. Please do not discard waste material, including packaging, in the surrounding environment. Follow all relevant legislation for disposal.

IMPORTANT:

Winn & Coales (Denso) Ltd pursue a policy to develop and continually improve all of our products and therefore information given in this data sheet is intended as a general guide and does not constitute a warranty, specification or risk assessment. These guidelines may not cover all circumstances; however, our sales personnel are committed to assisting the user in establishing the suitability of the product for its intended purpose and additional specific information, including Safety Data Sheets, is available on request. We recommend that installation is carried out with due regard to Health and Safety and in accordance with relevant local statutes and regulations. Any conflict between these guidelines and the specific project specifications must be resolved by the user before work commences. All rights reserved.