

The following guide is intended to demonstrate the best way to wrap a steel or cast iron valve using The Denso Petrolatum Tape & Mastic System. This system comprises Denso Profiling Mastic used to fill the voids and smooth the contours prior to overwrapping with Denso or Densyl Petrolatum Tape. This system can then be protected against mechanical damage by the use of a suitable Denso outerwrap.

Because the shapes and sizes of valves vary so much the illustrations are not drawn to scale and are intended to be used for reference only.

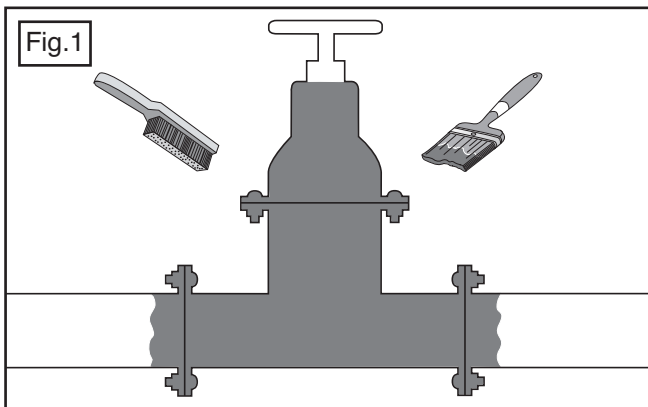

Fig. 1. Clean the valve so that it is free of loose dirt and grease. Remove any thick rust by hand power tool method.

Next, brush apply a coat of Denso Priming Paste or Priming solution to the entire surface to be protected.

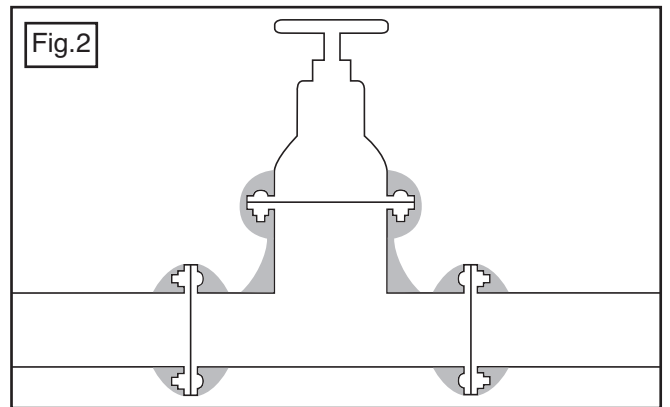

Fig. 2. Fill all voids with Denso Profiling Mastic and build up the profile around the valve flanges and shoulders so that there are no sharp angles.

This is to facilitate easy tape wrapping and reduce air entrapment.

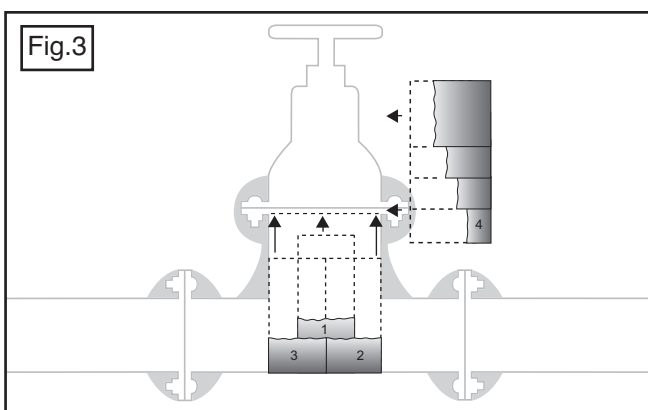
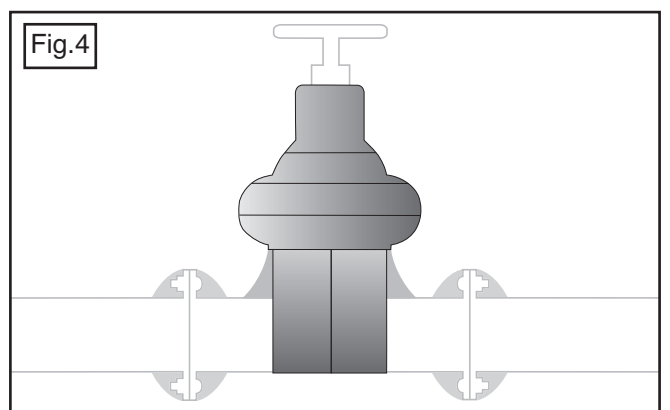

Fig. 3. Measure and cut the first pieces (1 to 3) of tape and then apply them to the valve body, following the numerical sequence shown in the diagram. These vertical tape pieces go right around the bottom of the valve and up the opposite side forming a 'U' shape. When applied in this manner the tape forms a double layer over the centre of the valve body.

The number of tape pieces used in this stage should be adjusted in accordance with the width of the tape used and the size of the valve.

The horizontal piece (4) of tape is spirally wrapped around the valve top. Starting from below the valve shoulder and covering the ends of the vertical tape pieces in a weatherboard manner and then working up towards the top of the valve. Make sure the tape does not interfere with the movement of the valve wheel or mechanism. Smooth down the tape and its edges to remove air and form a seal.

Fig. 4. The first pieces of tape in position.



Continued overleaf...

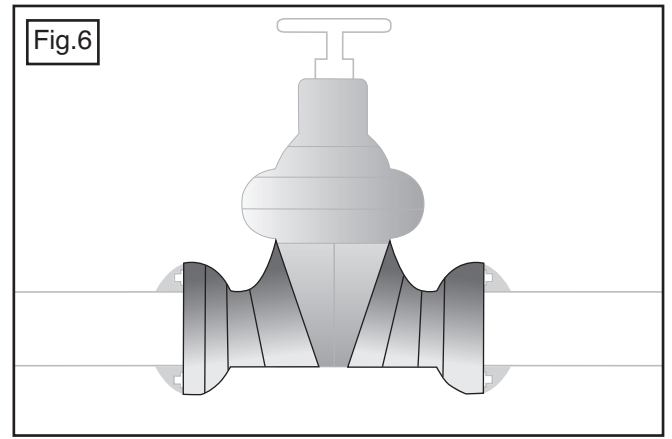
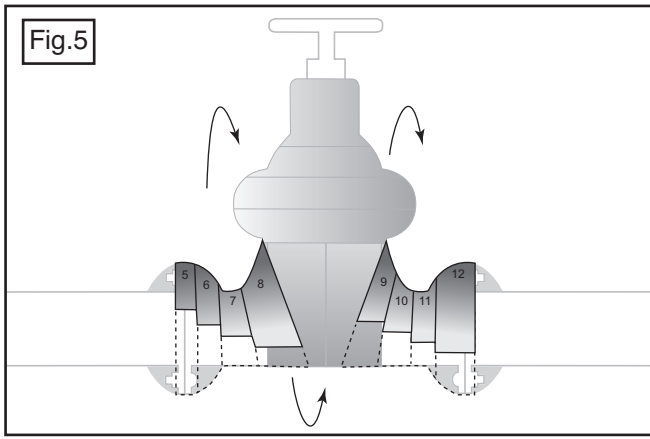

Fig. 5. Here the tape is applied directly from the roll in one continuous piece and the numbers on the diagram refer to the number of circumferential wraps. The tape should be applied using a 55% overlap to give a double layer. Starting at the top of the centre of the valve flange on one side and moving towards the valve body, wrap the first few turns vertically whilst gradually moving to a diagonal direction as the tape approaches and overlaps onto the previously applied tape pieces. Take the tape diagonally across the centre of the valve and continue on the other side working towards the opposite flange in a repeat of the first side. Smooth down the tape and its edges to remove air and form a seal.

The number of circumferential wraps used in this stage should be adjusted in accordance with the width of the tape used and the size of the valve.

Fig. 6. The completed wrap.

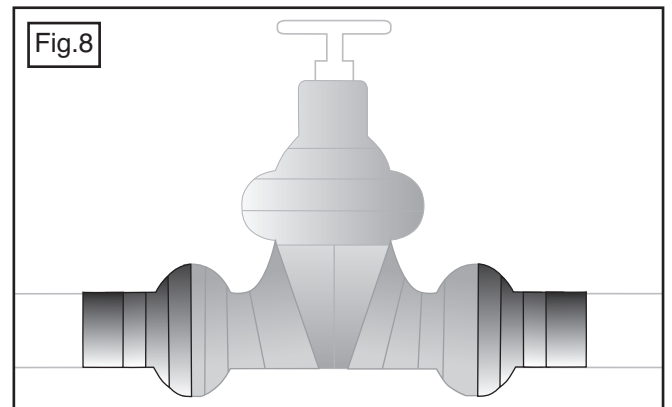
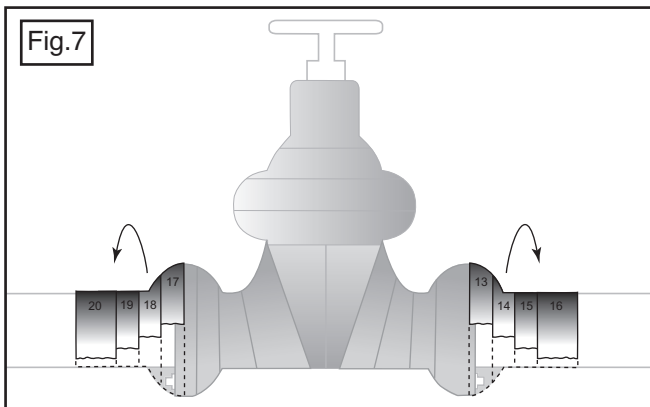

Fig. 7. The final tape wrap starts on the top of the centre of the flange and overlaps onto the previous tape. Working away from the flange onto the connected pipework in a vertical motion, the tape is applied using a 55% overlap to give a double thickness. This application is repeated on the other side of the valve to complete the wrapping. Smooth down the tape and its edges to remove air and form a seal.

Fig. 8. The completed tape wrap.

Tape Outerwraps:

If a Denso tape outerwrap is specified for mechanical protection purposes, it should be applied in an identical manner as shown for the petrolatum tape.

Take particular care to apply adequate tension whilst wrapping to remove air and seal all of the tape edges down firmly to finish the job.



Winn & Coales (Denso) Ltd, Denso House, Chapel Road, London SE27 0TR

TEL: +44 (0)20 8670 7511 FAX: +44(0)20 8761 2456 EMAIL: mail@denso.net WEB: www.denso.net

